

DEPARTMENT OF THE ARMY TECHNICAL BULLETIN

MICROPHONE M-52/U AND M-52A/U

Headquarters, Department of the Army, Washington 25, D.C.

26 May 1961

TB SIG 330, 15 April 1958, is changed as follows:

Change the title to **MICROPHONE M-52/U AND M-52A/U**.

Add the following note immediately above paragraph 1:

Note. Microphone M-52A/U, procured on Order No. 4656-PP-61 is essentially the same as Microphone M 52/U, except that some of the components have slightly different dimensions.

BY ORDER OF THE SECRETARY OF THE ARMY:

G. H. DECKER,
*General, United States Army,
Chief of Staff.*

Official:

R. V. LEE,
*Major General, United States Army,
The Adjutant General.*

Distribution:

Active Army: To be distributed in accordance with DA Form 12-7 requirements for TB SIG-series (Unclass) plus the following:

DASA (2)	11-7 (2)	32-67 (2)
USASA (2)	11-16 (2)	39-51 (2)
CNGB (1)	11-55 (2)	39-52 (2)
Tech Stf, DA (1)	11-57 (2)	44-435 (2)
except CSigO (46)	11-96 (2)	44-436 (2)
ARADCOM (2)	11-97 (2)	44-437 (2)
ARADCOM Rgn (2)	11-98 (2)	44-445 (2)
MDW (1)	11-117 (2)	44-446 (2)
Seventh US Army (2)	11-155 (2)	44-447 (2)
EUSA (2)	11-500 (AA-AE) (RA-RT) (4)	44-448 (2)
Units organized under following	11-555 (2)	44-535 (2)
TOE's:	11-557 (2)	44-536 (2)
1-207 (2)	11-587 (2)	44-537 (2)
7 (2)	11-592 (2)	44-544 (2)
9-47 (2)	11-597 (2)	44-545 (2)
9-87 (2)	29-51 (2)	44-546 (2)
9-227 (2)	29-55 (2)	44-547 (2)
9-377 (2)	29-56 (2)	44-548 (2)
9-500 (AA-AC) (2)	32-56 (2)	57 (2)
11-5 (2)	32-57 (2)	

NG: State AG (3).

USAR: None.

For explanation of abbreviations used, see AR 320-50.

MICROPHONE M-52/U

Headquarters, Department of the Army, Washington 25, DC

15 April 1958

1. Scope. *a.* This technical bulletin describes Microphone M-52/U and covers its operation and maintenance.

b. TM 11-2062 is applicable and available to the field and depot repairman of Micro phone M-52/U.

c. Forward all comments on this publication directly to Commanding Officer, U. S. Army Signal Publications Agency, Fort Monmouth, New Jersey.

2. Forms and Records. *a. Unsatisfactory Equipment Reports.*

(1) Fill out and forward DA Form 468, Unsatisfactory Equipment Report, to Commanding Officer, U. S. Army Signal Equipment Support Agency, Fort Monmouth, New Jersey, as prescribed in AR 700-38.

(2) Fill out and forward AFTO Form 29, Unsatisfactory Report, to Commander, Air Materiel Command, Wright-Patterson Air Force Base, Ohio, as prescribed in AFTO 00-35D-54.

b. Report of Damaged or Improper Shipment. Fill out and forward DD Form 6, Report of Damaged or Improper Shipment, as prescribed in AR 700-58 (Army); Navy Shipping Guide, Article 1850-4 (Navy); and AFR 71-4 (Air Force).

c. Preventive Maintenance Forms (fig. 2 and 3). Prepare DA Form 11-240 (Maintenance Check List for Signal Equipment (Telephone Set, Handset, Headset, and Chestset)), in accordance with instructions on page 1 of the form.

3. Purpose and Use. Microphone M-52/U provides push-to-talk microphone facilities for general purpose use with radio and telephone equipment.

A flexible cable permits freedom of movement while transmitting.

4. Technical Characteristics.

Impedance.....40 to 100 ohms.

Frequency300 to 4,000 cps.

Current requirements.....60 ma dc.

Frequency response Not less than 45 db above limits. a zero reference level of .001 volt across 100 ohms at 1,000 cps.

5. Description (fig. 1). Microphone M-52/U is a hand-held, unidirectional, carbon-type microphone with a 6-foot cable that terminates in a type PJ-068 plug. Molded finger-grip depressions are on the front of the microphone; a rubber-covered push-to-talk switch is on the back. Microphone Unit M-51/UR is clipped into the upper part, and at the top is a metal loop used to hang up the microphone when not in use. Microphone M-52/U, excluding the cable and plug, is 5-5/8 inches high, 3 inches deep, and 1 inch wide. Its weight, including cable and plug, is 15 ounces.

6. Operating Instructions (fig. 1). *a.* Connect Microphone M-52/U to the equipment to be used by inserting the plug into the proper jack.

b. Hold the microphone in the right hand with the thumb against the push-to-talk switch.

c. To transmit, hold the microphone so that the top of the handle rests against the cheekbone with Microphone Unit M-51/UR close to the mouth.

d. Press in the push-to-talk switch firmly with the thumb.

e. Talk into the microphone in a loud, clear voice.

f. Release the push-to-talk switch after transmission.

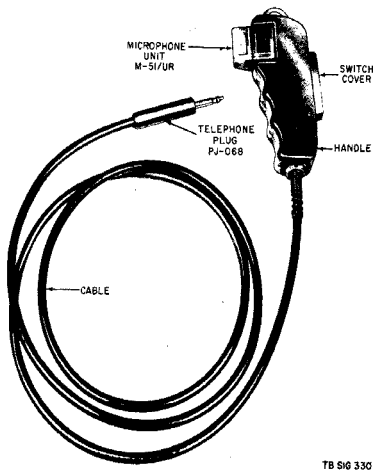

TB SIG 330-1

Figure 1. Microphone M-52/U.

Figure 1. Microphone M-52/U.

7. Organizational Tools and Materials. The following tools and materials are required for organizational maintenance of the equipment:

- Tool Equipment TE-41.
- Lint-free cloth
- Chamois.
- Brush
- Cleaning Compound (FSN 7930-395-9542).

8. Preventive Maintenance. a. DA Form 11-240 is the preventive maintenance check list. Items not applicable on this form have been lined out in figures 2 and 3.

b. The operator is responsible only for items 1 through 9 on DA Form 11-240. Should the operator's inspection or check for normal operation reveal any damage or malfunctioning, the equipment should be referred to the second-echelon repairman. In addition to items 1 through 9, the second-echelon

repairman is responsible for item 14. When performing item 14, the equipment should not be. Disassembled.

c. To check the microphone for proper operation, operate it in accordance with paragraph 6, and be sure that transmission is satisfactory.

9. Field Maintenance. a. *Scope.* Field maintenance includes the items specified on DA Form 11-240 for organizational maintenance, as well as repair and final testing of the microphone. The field maintenance repairman is responsible for performing items 13 and 16 on DA Form 11-240 only when the equipment is disassembled for repair.

b. *Tools and Test Equipment.* Tools and test equipment required for field maintenance of Microphone M-52/U are as follows:

- Tool Equipment TE-49.
- Multimeter AN/URM-105 or equal.
- Telephone Test Set AN/PTM-6 (TM 11-2062)

MAINTENANCE CHECK LIST FOR SIGNAL EQUIPMENT TELEPHONE SET, HANDSET, HEADSET AND CHESTSET <small>(AR 750-625)</small>			
EQUIPMENT NOMENCLATURE			
MICROPHONE M-521U			
EQUIPMENT SERIAL NUMBER			
<p align="center">INSTRUCTIONS</p> <p>This form may be used for a period of one month by using the correct dates and weeks of the month. It is to be used as a Preventive Maintenance check list for Signal equipment in actual use, or for a check on equipment prior to issue.</p> <ol style="list-style-type: none"> For detailed Preventive Maintenance instructions see: <ol style="list-style-type: none"> The Technical Manual (in <i>TN II series</i>) for the equipment. (See <i>DA Pamphlet Number 310-4</i>) The Supply Bulletin (in <i>SB 11-100 series</i>) for the equipment. (See <i>DA Pamphlet Number 310-4</i>) The Department of the Army Lubrication Order. (See <i>DA Pamphlet Number 310-4</i>) The following action will be taken by either the Communications Officer/Chief for 1st echelon, or the Inspector for higher echelon: <ol style="list-style-type: none"> Enter Equipment Nomenclature and Serial Number. Strike out items that do not apply to the equipment. Operator/Inspector will enter in the columns entitled CONDITION, on the proper line, a notation regarding the condition, using symbols specified under LEGEND. After operator completes each daily inspection he will initial over the appropriate dates under "Daily Condition for Month", then return form to his supervisor. 			
TYPE OF INSPECTION			
OPER- ATOR	2/3 ECH- ELON	DATE	SIGNATURE
✓		7 JULY 57	J. Jones
	✓	31 July 57	B. Brown

4

DA FORM 11-240
MAY 57

REPLACES DA FORMS 11-240, 1 SEP 55 AND 11-241, 1 OCT 55, WHICH ARE OBSOLETE.

Figure 2. DA Form 11-240, pages 1 and 4.

10. Trouble-shooting Chart. Use the chart to localize and correct troubles within Microphone M-

52/U. Refer to the schematic diagram (fig. 5) for wiring connections.

Symptoms	Probable trouble	Correction
When plugged into transmitting equipment and push-to-talk switch is pushed in, microphone is dead or transmissions is unsatisfactory	Defective associated equipment----- Loose or disconnected wiring----- Dirty, bent, or defective microphone unit contacts.	Check associated equipment. Check all wiring. Repair or replace as necessary. Pull out microphone unit and check contacts. Clean, bend upward, or replace if defective. Replace Microphone Unit M51/UR.
Push-to-talk switch cannot be pushed in when operator is ready to transmit.	Defective Microphone Unit M-51/UR. Defective connecting plug----- - Defective switch----- --	Replace plug. Replace switch.

11 . Disassembly (fig. 4). *a. Micro phone Unit M-51 /UR.*

(1) Snap the microphone unit (2) out of the clip (6) by rotating it counterclockwise with the thumb and index finger of the left hand. Pull off the cover (1).

(2) Remove the screws (7), washers (3), contacts (4), insulator (5), and the clip (6)

b. Switch

(1) Remove the screws (11) that hold the clamp (8); remove the clamp and switch cover (9).

(2) Lift the switch (10) out of the cavity in the microphone handle. Tag and unsolder the three leads (fig. 5) from switch terminals (1, 3, and 4).

c. Cable (fig. 4).

(1) Remove the staycord screw (17), and crimp terminal (16). Pry the staycord from the terminal.

(2) Remove the binding-head screws (13 and 15) and the crimp terminals (12 and 14). Pry the terminals from the wires.

(3) Unscrew the stud (22), and remove the cable (26), the strain-relief spring protector (23), the washer (24), and the bushing (25).

d. Plug (fig. 4).

(1) Unscrew the sleeve (18) from the body (19) of the plug, and slide the sleeve back over the cable (26).

(2) Remove the screws (21) and terminals (20) from the body of the plug (19).

(3) Unsolder the wires of the cable (26) from the terminals (20).

(4) Pull the sleeve (18) from the cable (26).

12. Reassembly (fig. 4). *a. Plug.*

(1) Slide the sleeve (18) back on the cable (26) frequency

(2) Solder the cable wires to the terminals (20).

(3) Use the screws (21) to attach the terminals (20) to the body (19) of the plug. Connect the white wire to the tip, the red wire to the ring, and the black wire to the sleeve.

(4) Screw the sleeve (18) back on the body (19) of the plug.

b. Cable (fig. 4).

(1) Run the free end of the cable (26) through the stud (22),- the strain-relief spring protector (23), the washer (24), and the bushing (25). Then screw the stud (22) into the microphone handle.

(2) Crimp the red wire to terminal (14) and the blue wire to terminal (12). Crimp the staycord to terminal (16). Secure terminals (12, 14, and 16) to the microphone handle using screws (13, 15, and 17). Be sure the staycord is held tightly in place.

c. Switch (fig. 4).

(1) Solder the blue, white, and black wires (fig. 5) to switch terminals (1, 3, and 4), respectively. Be sure the two small switch terminals are strapped together.

(2) Refer to figure 4 and attach the switch cover (9) to the switch (10), and set the switch in the microphone handle cavity.

(3) Set the clamp (8) over the switch, and secure it in place with the two screws (11). Be sure that the switch cover does not protrude from under the clamp.

d. *Microphone Unit M-51/UR (fig. 4).*

- (1) Set the clip (6), insulator (5), contacts (4), and flat washers (3) in place in the micro

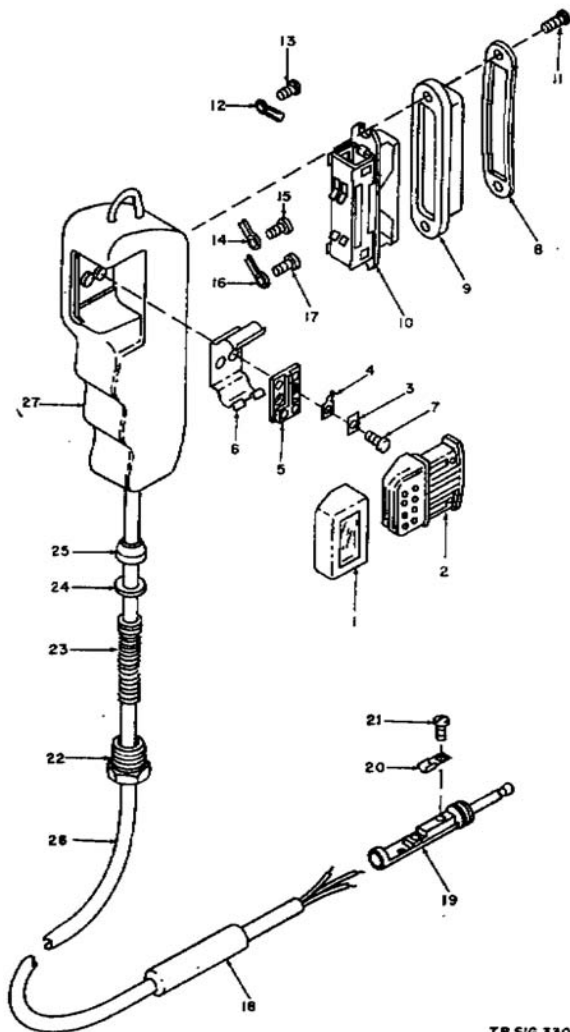

TB SIG 330-3

TB SIG 330-3

Figure 4. Microphone M-52/U, exploded view

1. Microphone cover (MPI).
2. Microphone Unit M-51/UR (MK1).
3. Washer (H1) (2 supplied)
4. Contact (E1) (2 supplied)
5. Insulator (E2).
6. Clip (E3).
7. Screw, binding head, slot drive, brass, 0.086 in. od, 56 threads per in. By .125 in. long (H2) (2 supplied).
8. Clamp (MP2).
9. Switch cover (MP3).
10. Switch (S1).
11. Screw, binding head, slot drive, brass, .112 in. od, 40MP4). threads per in. By .375 in. Long (H3) (2 supplied).
12. Crimp terminal (H4).
- 13.. Handle (MP5).
14. Crimp terminal (H4).
15. Screw (same as item 7) (H2).
16. Crimp terminal (H4).
17. Screw (same as item 7) (H2).
18. Sleeve (part of P1).
19. Body (part of P1).
20. Terminal (part of P1).
21. Screw, binding head, slot drive, brass, No. 2-30 by 3/16 in. long (part of P1) (3 supplied).
22. Stud (H2).
23. Spring protector (MP4).
24. Washer (H7).
25. Bushing (H8).
26. Cable (W1).
27. Handle (MP6).

phone cavity, and secure them in place with the screws (7). Be sure the contacts point up toward the microphone handle hanger.

- (2) Push the cover (1) on the microphone unit (2).
- (3) Snap the microphone unit (2) into the clip (6) so that the unit contacts will set firmly against the contacts (4) in the cavity.

13. Final Testing a Test Equipment. Build a test jig by using an insulated clip and contacts from a spare microphone handle (fig. 4). Solder an insulated 20 gage copper wire, 2 feet long, to each contact. Strip about 1 inch of insulation from each wire at the unsoldered ends. Use Telephone Test Set AN/PTM-6 for the efficiency and noise cancellation tests; use Multimeter AN/URM-105 for the voltage and current tests on the switch.

b. Efficiency Test. Place Microphone Unit M-51/UR in the test jig (a above). Turn on the test set and allow 5 minutes for it to warm up. Attach one lead from the test jig to the TRANS binding post and the other lead to the COMM binding post. Set the test set controls as follows: key 1 to CBPE, key 2 to RCT, key 7 to AC, switch D1 to 2, switch D3 to 4, switch D5 to 1 and EQUALIZER switch S2 to IN. Precondition the microphone by rotating it back and forth about its central axis, and set the face of the microphone against the sound source screen. Hold key 8 at the TRANS position and press in on Key 9. The meter should read to the right of -8 decibels (db).

c. Noise Cancellation Test. Place the end of the microphone against the sound source screen,

hold key 8 at the TRANS position, and press in on key 9. The meter should read approximately 8 db to the left of the efficiency test reading.

d. *Voltage and Current Test.* Remove the switch from the switch cavity (par. 11b) but do not unsolder the wires. Connect Microphone M-52/U to its associ-

ated transmitting equipment. Use Multimeter AN/URM-105 to check voltage and current at the switch terminals (fig. 5). With the switch in the transmitting position, voltage should not exceed 30 volts, and current should not exceed 1 ampere.

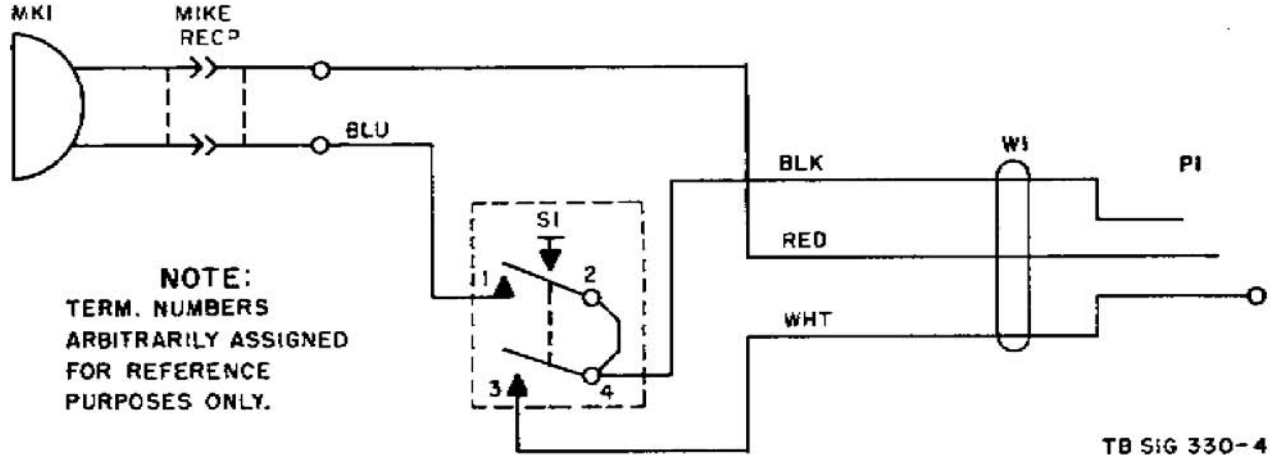

Figure 5. Microphone M-52/U, schematic diagram

By Order of Wilber M. Brucker, Secretary of the Army:

MAXWELL D. TAYLOR
General, United States Army,
Chief of Staff.

Official:

HERBERT M. JONES,
Major General, United States Army,
The Adjutant General.

Distribution:

Active Army:

- CNGB
- ASA
- Technical Stf, DA
- Technical Stf Bd
- USCONARC
- USA Arty Bd
- USA Armor Bd
- USA Armor Bd Test Sec
- USA Inf Bd
- USA Air Def Bd
- USA Air Def Bd Test Sec
- USA Abn & Elct Bd
- USA Avn Bd
- USA Arctic Test Bd
- US ARADCOM
- OS Maj Comd
- Log Comd
- MDW
- Armies
- Corps
- USATC
- Ft & Camps

NG: State AG; units—same as Active Army.

USAR: None.

For explanation of abbreviations used, see AR 320-50.

- USASCS
- USMA
- Gen Depots
- Sig Sec, Gen Depots
- Sig Depots
- AH
- WRAMC
- BAMC
- AFIP
- AMS
- TASSA
- Mid-Western Rgn Ofc (TASSA)
- Army Pictorial Cen
- USA Comm Agcy
- Engr Maint Cen
- USA Sig Comm Engr Agcy
- USA Sig Pub Agcy
- USA White Sands Sig Agcy
- Ports of Emb (OS)
- Trans Terminal Comd
- Army Terminals
- OS Sup Agcy

- PG
- USA Elct PG
- Arsenals
- Plant & Works
- Sig Fld Maint Shops
- Lab
- Mil Dist
- Sectors, USA Corps (Res)
- USA Corps (Res)
- JBUSMC
- Units organized under following TOE's:
- 11-7, Sig Co, Inf Div
- 11-16, Hq & Hq Co, Sig Bn, Corps or Abn Corps
- 11-57, Armd Sig Co
- 11-127, Sig Rep Co
- 11-128, Sig Depot Co
- 11-500 (AA-AE), Sig Svc Org
- 11-557, Abn Sig Co
- 11-587, Sig Base Maint Co
- 11-597, Sig Base Depot Co